

Product details: LAF Classic

Dimensions	220 mm x 660 mm x 690 mm
Weight	59.75 lbs (27.1 kg)
Power	1st: 110 V-120V, 60Hz, Max: 2,000W 16A
Power plug US	N5/20
Package Dimensions	78cm x 35cm x 65.6cm
Dispense Speed	1.6 quarts in 60 seconds
Water Supply	Water treatment: Drinking water without undissolved solids. Mechanical filtration of 10 µm; carbonate hardness 7°dKH Connection: 3/8 Female connector Pressure > 0.1 MPa < 1 MPa
Water Drainage	yes, 1x 6mm drain tube (0.24 inches)
Counterspace	Leave at least 7.9 inches free space behind machine for proper ventilation and connections cutout.
Environment	Humidity 80%, no condensation Temperature +41 °F to +95 °F.

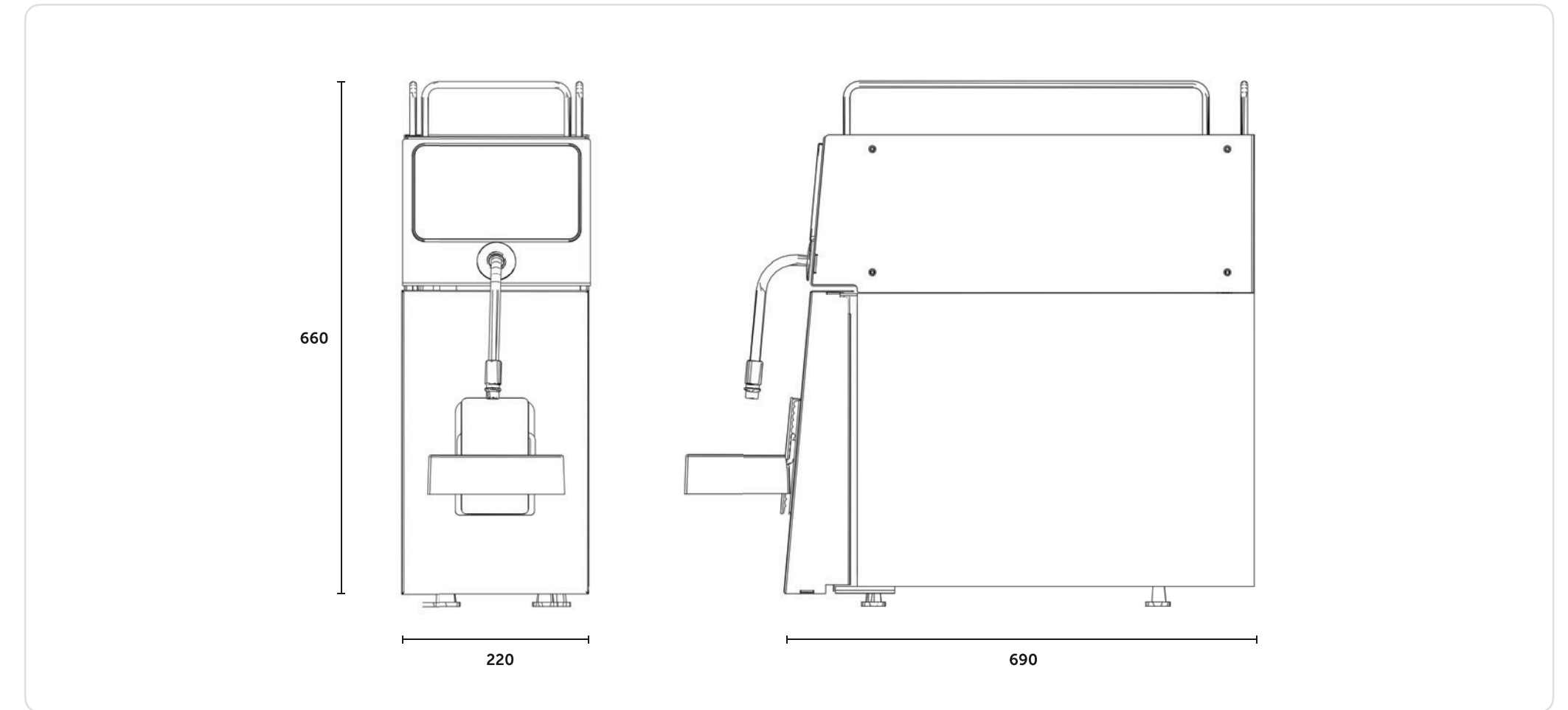

LAF Classic – full unit on counter



Dimensions (WxHxD): 220 mm x 660 mm x 690 mm

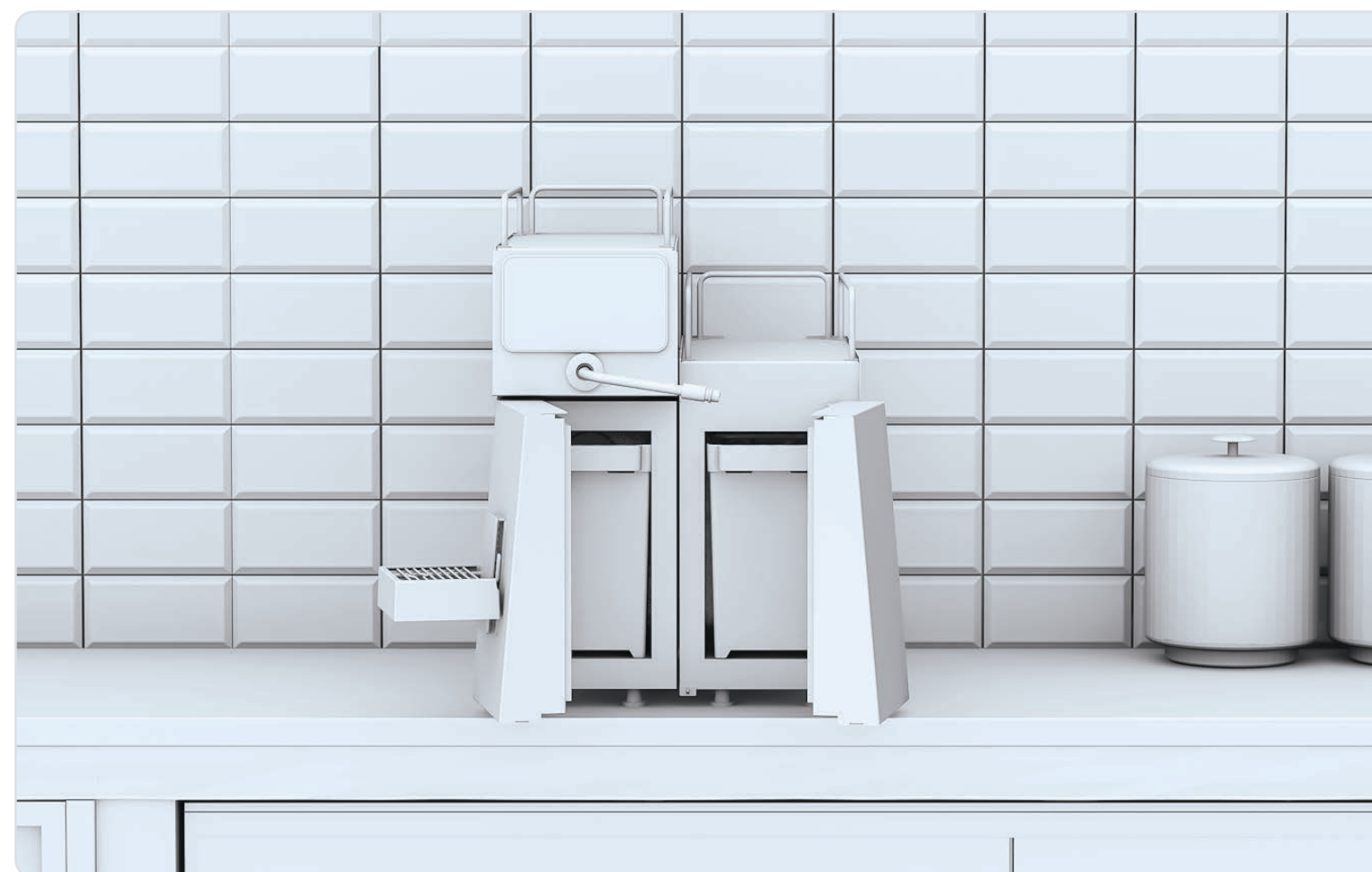

Standard fridge with 1 gallon container



Extra fridge setup: 2x 1 gallon containers